

EBS Filters

The largest automatic self-cleaning filter for fine filtration



flowrates

**up to 7200 m³/h
(32000 US gpm)**

filtration degrees

800-10 micron

water for cleaning

**less than 1%
of the total flow**

minimum operating pressure

2 bar (30 psi)

features:

- Large filtration area, reliable operating mechanism and simple construction make the EBS filter the ideal solution for filtration of high-flow and poor quality water to very finefiltration degrees
- Automatic flushing according to pressure differential and/or time
- No interruption of downstream flow during flushing
- Robust and reliable self-cleaning mechanism even on marginal operation conditions
- Minimal volume of reject water allows excellent operation during flush mode
- Applications: Water supply systems, Irrigation systems, Cooling Water, Wastewater Treatment, Industrial Pre-Filtration, etc.
- Industries: manufacturing, mining, water and wastewater treatment plants, turf and agriculture, etc.

How the EBS Filters Work

General

The Amiad EBS Series are automatic filters, with an electric self-cleaning mechanism.

The “EBS” filters range in flowrates of up to 7200 m³/h (32000 US gpm), with screens designed ranging from 800-10 micron filtration degree. Inlet/Outlet flanges are available from 8” -36” diameter.

The Filtering Process

Raw water enters from the filter inlet (1) and passes through the screen (2). Clean water flows through the filter outlet (3). The gradual dirt buildup on the inner screen surface causes a filter cake to develop, with a corresponding increase in the pressure differential across the screen. A pressure differential switch (4) senses the pressure differential and when it reaches a pre-set value, the cleaning process begins.

The Self-Cleaning Process

Cleaning of the filter is carried out by the suction scanner (5) which spirals across the screen, the open exhaust valves creates a high velocity suction stream at the nozzle tip which “vacuums” the filter cake from the screen. During the self-cleaning process, which takes approximately 30 seconds, filtered water continues to flow downstream.

The Control System

The “EBS” operation and cleaning cycle is controlled and monitored by a Programmable Logic Control (PLC). The PLC allows maximum flexibility in control options and has many features that can be incorporated per customer’s needs. During the self-cleaning cycle the PLC controls a solenoid that operates the exhaust valve by means of a hydraulic command or compressed air.

The self-cleaning cycle begins under any one of the following conditions:

1. Receiving a signal from the Pressure Differential Switch
2. Time interval parameter set at the control board
3. Manual Start

The control board also provides:

- Optional continuous flush mode
- Flush cycles counter
- Alarm output – may be used to open a bypass, shut-off a pump, etc.

“EBS” Models

Amiad’s “EBS” product-line consists of the following models:

- EBS-10000 for up to 1200 m³/h (5300 US gpm)
- EBS-15000 for up to 1800 m³/h (8000 US gpm)
- Mega EBS 40000 which consists of four EBS-10000 screen elements for up to 4800 m³/h (21100 US gpm)
- Mega EBS 60000 which consists of four EBS-15000 screen elements for up to 7200 m³/h (32000 US gpm)

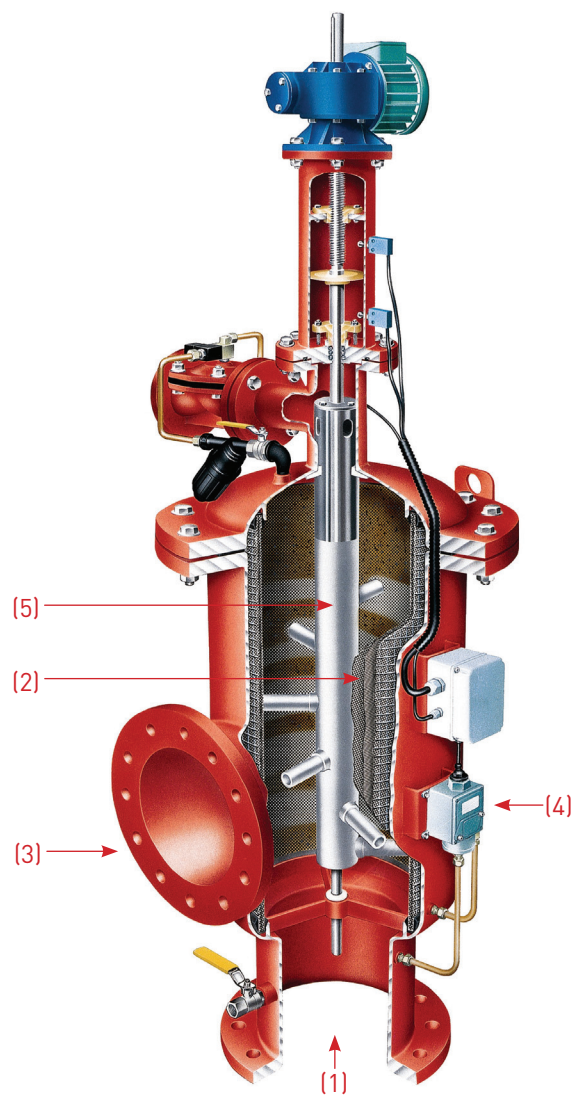

EBS 10000



ON-LINE

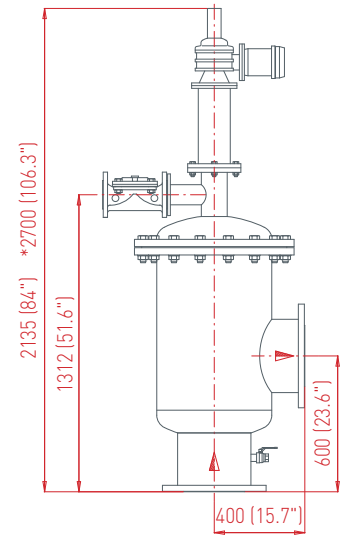

EBS 15000

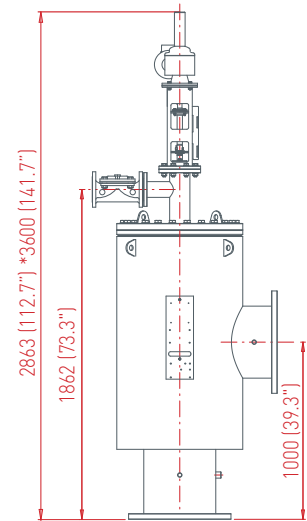
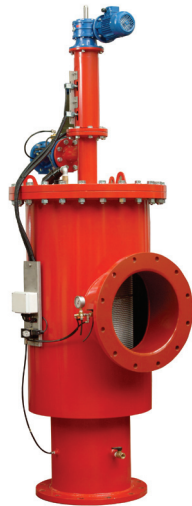

MEGA EBS 40000

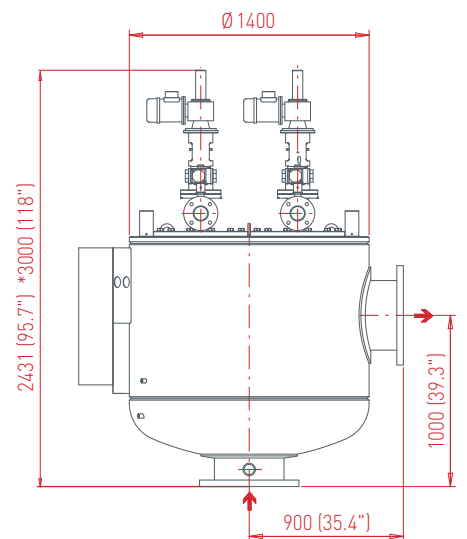

Dim: mm (inch)

*Approx. length required for maintenance

IN-LINE

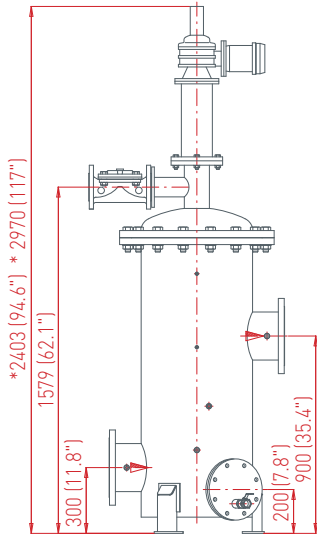

Head Loss Graphs in clean water

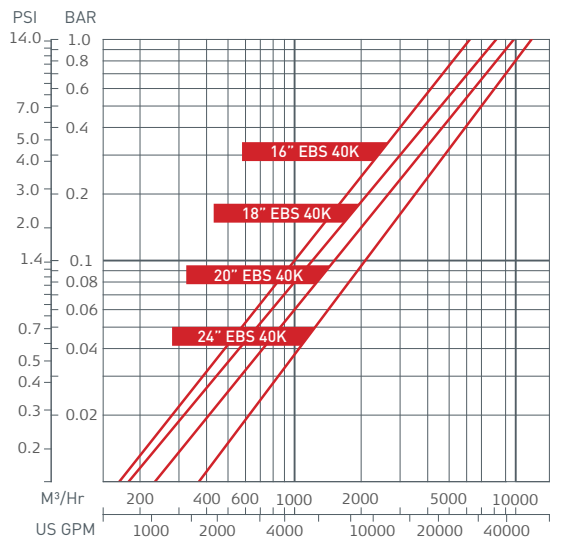
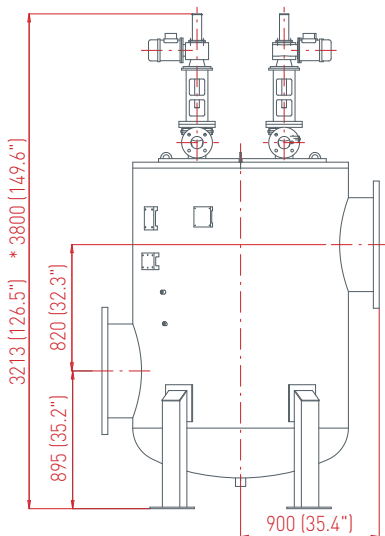
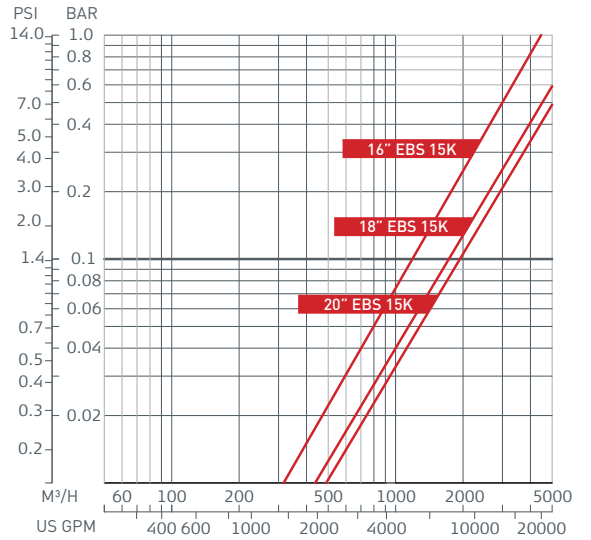
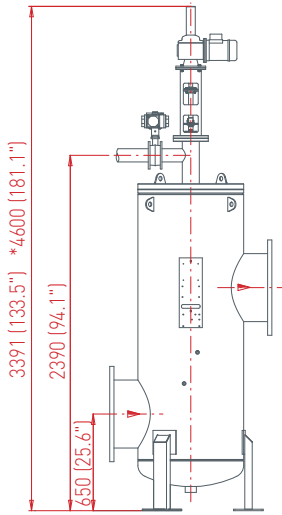
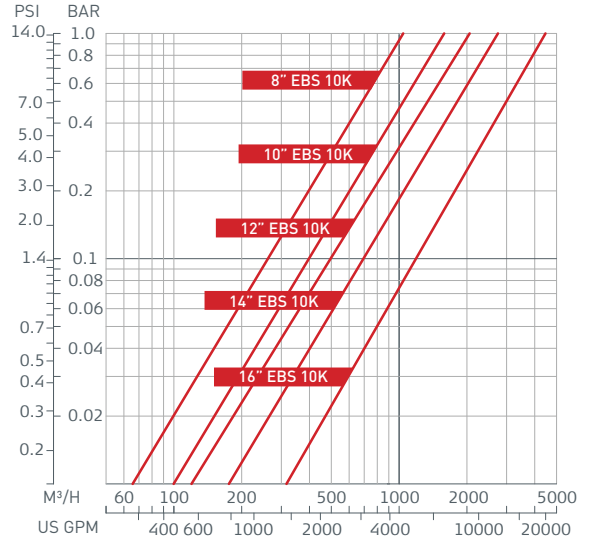

Dim: mm (inch)

*Approx. length required for maintenance

Technical Specifications

| Filter Type | EBS 10000 | EBS 15000 | Mega EBS 40000 | Mega EBS 60000 |
|-------------|-----------|-----------|----------------|----------------|
|-------------|-----------|-----------|----------------|----------------|

| General Data | | | | |
|----------------------------------|--|---|--|--|
| Maximum flowrate* | 1200 m ³ /h (5300 US gpm) | 1800 m ³ /h (8000 US gpm) | 4800 m ³ /h (21100 US gpm) | 7200 m ³ /h (32000 US gpm) |
| Inlet/Outlet diameter | 8"-16" (200-400 mm) | 10"-20" (250-500 mm) | 16"-24" (400-600 mm) | 20"-36" (500-900 mm) |
| Standard filtration degrees | Weave Wire Screen 800, 500, 300, 200, 130, 100, 80,50, 25, 10 micron | | | |
| Min. working pressure | 2 bar (30 psi) | | | |
| Max. working pressure | 10 bar (150 psi) 16 bar (232 psi) upon request | | | |
| Max. working temperature | 60°C (140°F) | | | |
| Electrical supply | 3 phase, 220/380/440 VAC 50/60 Hz | | | |
| Weight [empty on-line models] | 490 kg (1080 lb) | 684 kg (1508 lb) | 2250 kg (4960 lb) | 6200 kg (13670 lb) |

* Consult Amiad for optimum flow depending on filtration degree & water quality

| Flushing Data | | | | |
|--|---|--------------------------------------|---|--|
| Minimum flow for flushing (at 2 bar - 30 psi) | 50 m ³ /h (220 US gpm) | 50 m ³ /h (220 US gpm) | 50 or 200 m ³ /h (220 or 880 US gpm)* | 50 or 200 m ³ /h* (220 or 880 US gpm)* |
| Reject water volume per flush cycle | 420 liter (111 US gallon) | 500 liter (132 US gallon) | 1680 liter (444 US gallon) | 2000 liter (528 US gallon) |
| Flushing cycle time | 30 seconds | 36 seconds | 30 or 120 seconds* | 144 or 36 seconds* |
| Exhaust valve | 3" (80 mm) | 3" (80 mm) | 4 units of 3" (4 units of 80 mm) | 4 units of 3" (4 units of 80 mm) |
| Flushing criteria | Differential pressure of 0.5 bar (7 psi), time intervals and manual operation | | | |

*One by one or all four screens simultaneously

| Screen Data | | | | |
|--------------|--|--|--|--|
| Filter area | 10000 cm ² (1500 in ²) | 15000 cm ² (2325 in ²) | 40000 cm ² (6200 in ²) | 60000 cm ² (9300 in ²) |
| Screen types | Four-layer Weave Wire stainless steel 316L | | | |

| Control and Electricity | | | | |
|---|-----------------------------------|---------|----------|----------|
| Rated operation voltage | 3 phase, 220/380/440 VAC 50/60 Hz | | | |
| Electric motor 20 / 24 Gear output RPM | ½ HP | ½ HP | 4 x ½ HP | 4 x ½ HP |
| Current consumption | 1.5 Amp | 1.5 Amp | 5 Amp | 5 Amp |
| Control voltage | 24 VAC | | | |

| *Construction Materials | |
|-------------------------|--|
| Filter housing and lid | Epoxy or Polyester coated carbon steel 37-2 |
| Cleaning mechanism | Stainless steel 316L, Acetal |
| Exhaust valve | Epoxy-coated cast iron, Natural rubber |
| Seals | Synthetic rubber, Teflon |
| Control | Aluminum, Brass, Stainless steel, PVC, Nylon |

* Amiad offers a variety of construction materials and screens. Please consult us for specifications

Headquarters

Amiad Water Systems Ltd. D.N. Gatil Elyon 1, 1233500, Israel,
Tel: 972 4 690 9500, Fax: 972 4 814 1159,
E-mail: info@amiad.com

America



Amiad USA Inc. Main Office and Manufacturing: 120-J Talbert Road, Mooresville, NC 28117,
Tel: 1 704 662 3133, Fax: 1 704 662 3155, Toll Free: 1 800 24 FILTER,
E-mail: info@amiadusa.com www.amiadusa.com

West Coast Sales Office and Warehouse:
2220 Celsius Avenue, Oxnard, California 93030
Tel: 805 988 3323, Fax: 805 988 3313, Toll Free: 1 800 969 4055

Chile

Amiad Andina, Carretera General San Martín 16.500 No 30,
Loteo Industrial Los Libertadores, Colina, Santiago de Chile,
Tel: 56 2 24895100, Fax: 56 2 24895101, E-mail: amiadandina@amiad.com

Brazil

Amiad Sistemas de Água Ltda., Av. Funchal, 411, Conj. 42, Vila Olimpia, São Paulo, CEP 04551-060
Tel: +55 11 31923824, E-mail: infobrasil@amiad.com

Amiad Oil & Gas, E-mail: amisur@adinet.com.uy

Mexico

Amiad Mexico SA DE CV,
Priv. Retorno 8, Lote 3, Mza. 1, Interlomas Estado de Mexico
Tel/Fax: +52 55 636 28122, E-mail: info@amiadmexico.com

Asia



India

Amiad Filtration India Pvt Limited, 305 Sai Commercial Building,
Govandi St Rd, Govandi Mumbai 400 088,
Tel: 91 22-67997813/14, Fax: 91 22-67997814, Email: info@amiadindia.com

China

Amiad China (Yixing Taixing Environtec Co., Ltd.) 70 Baihe Chang, Xingjie Yixing Jiangsu, 214204,
Tel: 86 510 87134000, Fax: 86 510 87134999, E-mail: marketing@taixing.cc

South-East Asia

Filtration & Control Systems Pte. Ltd., 19B Teo Hong Road, 088330 Singapore,
Tel: 65 6 337 6698, Fax: 65 6 337 8180, E-mail: amiad@amiad.com.sg

Australia



Amiad Australia Pty Ltd. 138 Northcorp Boulevard, Broadmeadows, Victoria 3047,
Tel: 61 3 93585800, Fax: 61 3 93585888, E-mail: sales@amiad.com.au

Europe



Amiad Water Systems Europe SAS, Ilot No4 ZI La Boitardière, 37530 Chargé, France,
Tel: 33 (0) 2 47 23 01 10, Fax: 33 (0) 2 47 23 80 67, E-mail: info@amiad-europe.com

Germany

Amiad Water Systems SAS Europe (German branch office)
Zweigniederlassung Deutschland Prinz-Regent-Str. 68 a 44795 Bochum,
Tel: 49 (0) 234 588082-0, Fax: 49 (0) 234 588082-10, E-mail: info@amiad.de

Turkey

FTS – Filtration & Treatment Systems, Istanbul yolu 26 Km, Yurt Orta Sanayii, Saray, Ankara,
Tel: 90 312 8155266/7, Fax: 90 312 8155248, E-mail: info@fts-filtration.com

