

**INSTALLATION INSTRUCTIONS FOR  
THE MODEL 777 ELECTRONIC OVERLOAD RELAY  
BE SURE POWER IS DISCONNECTED PRIOR TO INSTALLATION!  
FOLLOW NATIONAL, STATE AND LOCAL CODES!  
READ THESE INSTRUCTIONS ENTIRELY BEFORE INSTALLATION.**

The model 777 is a solid-state (electronic) overload relay. It is fully-programmable for customized protection. It is designed to protect three phase systems operating on voltages from 190 to 480 VAC (500-600VAC for 777-575). The output relay is a Form C contact, which can control a contactor or other device within the output relay contact rating. The unit can be programmed prior to installation by applying 120VAC to terminals 'L1' and 'L2' (except 777-575). The unit can NOT be tested for proper operation using this voltage. For testing purposes, three phase power needs to be used with a minimum voltage of 190VAC (450VAC for 777-575).

**DANGER!**

**HAZARDOUS VOLTAGES MAY BE PRESENT DURING INSTALLATION.**

Electrical shock can cause death or serious injury.

Installation should be done by qualified personnel following all national, state and local electrical codes.

**CONNECTIONS**

1. Disconnect power and verify power is off.
2. Using the four corner tabs or the DIN rail mount, mount the 777 directly above or below the contactor. To use the DIN rail mount, hook the top clip first then apply downward pressure until the lower clip 'clicks' onto the rail.
3. A) For amperages from 26-90 amps, insert the motor conductors through the holes marked 'A', 'B', and 'C'. Make certain that the conductor through each hole corresponds to the right motor conductor, i.e. the 'A' phase conductor should go through the 'A' round hole. See figure 1 for a typical wiring diagram.  
B) For amperages less than 26 amps, loop the motor conductors according to table 1. Figure 3 shows an example of the looping required for current ranging from 8.1 to 12 amps (MULT=3).  
C) For amperages greater than 90 amps, external CT's (current transformers) are required. SymCom recommends CT's with terminals be used for ease of installation. All CT secondaries must make five passes through the round holes on the MotorSaver. See figure 2 for a typical wiring diagram using external CT's.  
NOTE: Pay close attention to this diagram to eliminate any power factor errors when communicating with the device through the RS485 network.
4. Connect the three phase power from the line side of the contactor to 'L1', 'L2', and 'L3' terminals using 12-18AWG copper wire. These should be tightened to no more than 7 inch lbs.
5. Connect the control circuit wires to the appropriate terminals. The relay is a fail safe design so the 'NO' contact should be in series with the coil on the contactor for motor control (see figure 1). For alarm circuits, the 'NC' contact is in series with the alarm circuitry.

Full Load Amps	# of Loops	# of Conductors through A, B and C	MULT Setting (CT ratio)
2.0 - 2.5	9	10	10
2.6 - 3.0	8	9	9
3.1 - 3.5	7	8	8
3.6 - 4.0	6	7	7
4.1 - 5.0	5	6	6
5.1 - 6.0	4	5	5
6.1 - 8.0	3	4	4
8.1 - 12	2	3	3
13 - 25	1	2	2
26 - 90	0	1	1
<b>▼ EXTERNAL CTs REQUIRED. SEE FIGURE 2 FOR WIRING EXTERNAL CTs. ▼</b>			
91 - 110	4	5	100 (100:5)
111 - 160	4	5	150 (150:5)
161 - 220	4	5	200 (200:5)
221 - 320	4	5	300 (300:5)
321 - 420	4	5	400 (400:5)
421 - 520	4	5	500 (500:5)
521 - 620	4	5	600 (600:5)
621 - 800	4	5	800 (800:5)

**Table 1: Wiring Configuration Based on Motor Full Load Amps**

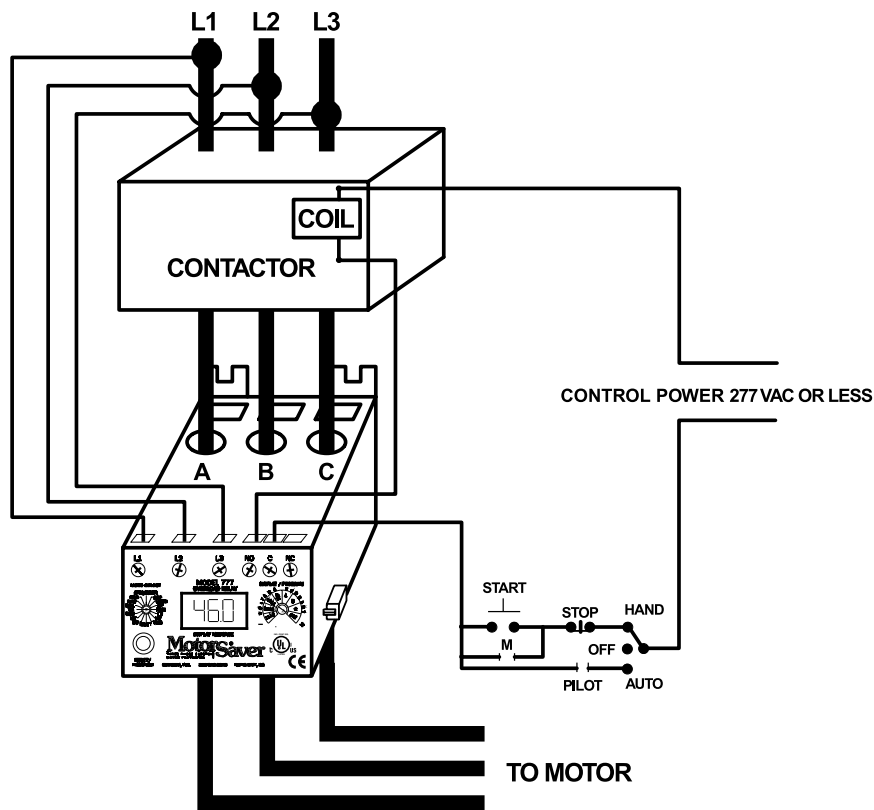

**Figure 1: Typical Wiring Diagram for FLA of 26-90**

**SYMCOM RECOMMENDS USING CT'S THAT HAVE TERMINALS TO MAKE CT INSTALLATION EASIER.**

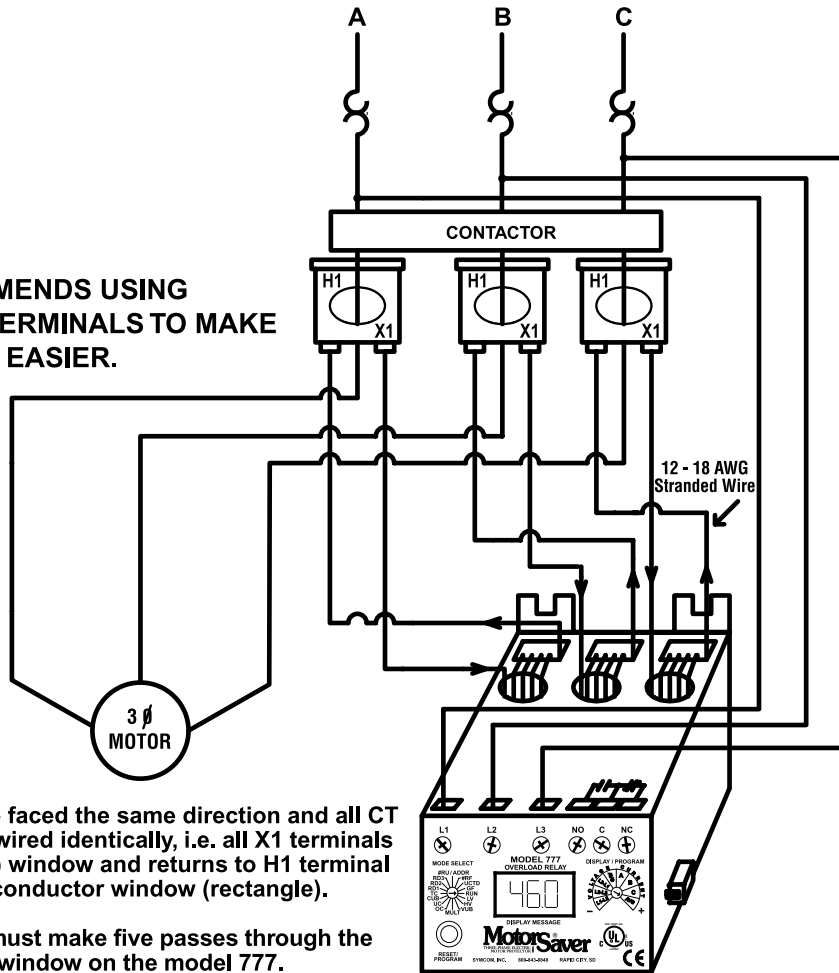

**Note: All CT's must be faced the same direction and all CT secondaries must be wired identically, i.e. all X1 terminals enter the main (round) window and returns to H1 terminal after exiting the loop conductor window (rectangle).**

**Every CT secondary must make five passes through the corresponding round window on the model 777.**

**Figure 2: Typical Wiring Diagram Using External CTs.**

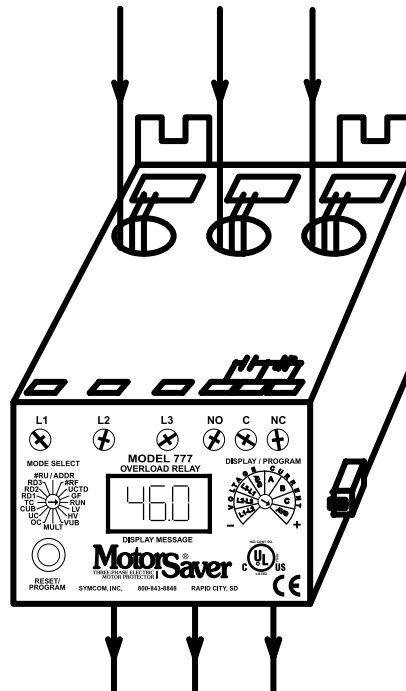

**Figure 3: Looping Example Showing Three Conductors (MULT=3 from table 1) (No other necessary connections are shown.)**

## **PROGRAMMABLE PARAMETERS**

The programmable parameters are the parameters which the user MUST program to provide the correct protection for the application. All parameters are actual values except for the “VUB” and the “CUB” settings. These are programmed as percentages. The range these parameters can be programmed to is found on the electrical specifications on page 11. See page 7 for programming examples.

**LV/HV** - The recommended settings for LV (low-voltage) and HV (high-voltage) according to the NEMA MG1 standard are  $\pm 10\%$  of the motors nameplate voltage. For other settings the motor manufacturer should be contacted. Example: The motor nameplate voltage is 230 volts. If we take 90% and 110% of 230 we get  $0.9 \times 230 = 207$  volts for the LV setting and  $230 \times 1.1 = 253$  volts for the HV setting. These parameters are based on the average voltage going to the motor.

**VUB** - VUB (voltage unbalance) is factory set at 6%. The NEMA MG1 standard says a motor should not be operated above a 1% voltage unbalance without **DERATING** the motor. Most utility supplied power sources have a difficult time sustaining a 1% VUB. The motor manufacturer should be consulted for an exact VUB setting. A setting of 999 for VUB will disable the VUB protection and SP (single phase protection).

The VUB is calculated as follows:

$$\%VUB = [(\text{Maximum deviation from the average})/\text{Average}] \times 100\%$$

**Example:** Measured line-line voltages = 203, 210, and 212, so the average =  $(203+210+212)/3 = 208.3$ , the maximum deviation from the average is the biggest difference between the average voltage (208.3) and any one voltage reading,  $212-208.3 = 3.7$ ,  $210-208.3 = 1.7$  and  $208.3-203 = 5.3$ , therefore the maximum deviation from the average is 5.3. The VUB is then =  $5.3/208.3 \times 100 = 2.5\%$

**MULT** - MULT (multiplier) setting is found from table 1. The MULT setting is determined by the current the unit will be monitoring. This allows the unit to display the correct current. Changing this setting will also change the “UC”, “OC”, and “GF” set points.

**OC**- OC (overcurrent) is usually set at the service factor amperage (typically 100-115% of motor FLA) of the motor, which is determined by the motor manufacturer. If any one leg of current exceeds the oc setting, the unit will start it's trip delay timer (see figure 4).

**UC** - UC (undercurrent) is typically set at 80% of the full-load amperage of the motor. This is usually adequate for protection of loss of load for many pumps and motors, including submersibles. If the motor is not pulling near full load amperage then the UC may have to be set to something higher than 80% of FLA for adequate protection. UC can be set to 0 if UC protection is not desired. The UC trip point looks at the average current to determine if an under current trip condition exists.

**CUB** - CUB (current unbalance) is factory set to 7%. SymCom recommends the motor manufacturer be contacted for an exact setting. The CUB is calculated the same way the VUB is determined above. The CUB protection can be disabled by programming a 999 in this setting. This will disable current unbalance protection and current single phasing protection.

**TC** - TC (trip class) is the parameter used to determine when the unit will trip when an overload condition is detected. For standard motors, the TC is typically set at 20. The motor manufacturer should be contacted for exact TC settings.

Table 2 and figure 4 show the range of TC settings and trip times.

**RD1** - RD1 (restart delay one) is the rapid cycle timer in seconds. This timer is initiated when power is first applied to the unit. If everything is okay (voltages are within the programmed limits and no SP or RP condition exists), after power is applied to the device and the RD1 time expires, the output relay will energize (the NO will close and the NC will open). Typically, this is set to 20-30 seconds. This will provide adequate protection for successive power outages or short cycling caused by other motor controls. This timer is also initiated when another control shuts the motor off (current goes to zero). If the user does not want the units' relay to de-energize when another control shuts the motor off, then RD1 should be set to zero. This will also assure that when an alarm circuit is used, an alarm will sound only when there is a true problem or when power is lost.

- RD2** - RD2 (restart delay two) is the restart timer, in minutes, used when the unit has shut off due to a current unbalance, current single phasing, or an overload condition (if "oc" is the prefix to the number in #RF, see #RF description). This timer is known as a motor cool down timer. A setting of 5-10 minutes will give most motors adequate time to cool down after an overload condition. The motor manufacturer should be contacted for an exact value.
- RD3** - RD3 (restart delay three) is the restart timer, in minutes, used after an undercurrent trip. It is also known as a dry well recovery time in pumping applications. This would be the time it takes a well to recharge after pumping dry. This setting varies widely from application to application and there is no typical setting.
- #RU** - The #RU/ADDR is a dual function setting. #RU can only be set to 0, 1, 2, 3, 4, or A. ADDR settings have the following format: Axx. The "xx" is any number combination from 01-99. This is how to identify which parameter is being programmed. The #RU settings cover from the 7 o'clock position to the 11 o'clock position. ADDR settings start after the 11 o'clock position. #RU (# of restarts after an undercurrent) is the number of restarts after an undercurrent trip condition before the unit locks and requires a manual restart. This counter will be cleared one minute after start-up if the unit does not trip again on UC. A setting of zero means no automatic restarts after an undercurrent. A setting of "A" means the unit will always automatically restart after an undercurrent.
- ADDR** - ADDR (address) is the RS485 address of the particular device. This is only used when communicating with an RM-2000 (set ADDR=A01), a PLC, or PC. The ADDR can be programmed from A01-A99.
- #RF** - #RF (# of restarts after a fault) is the number of restarts allowed after a current unbalance, current single phasing, or an overload condition. A setting, which includes an "oc" prefix, will include over current in the number of successive restarts. If "oc" is not a prefix to the programmed setting, the unit will require a manual restart after an over current. A setting of zero means the unit will not try to restart after a CUB, OC, or SP. A setting of "ocA" means the unit will always try to restart after a CUB, OC, or SP.
- UCTD** - UCTD (undercurrent trip delay) is the amount of time, in seconds, the unit will allow the motor to run in an undercurrent situation before de-energizing its relay. Typically, UCTD is set to 2-4 seconds.
- GF** - GF (ground fault) is the maximum allowable current, which can flow to ground before the unit de-energizes its relay. This is a residual, class II ground fault system and should not be used for personnel safety. A typical setting for this is 10%-20% of the motor full load current. The real GF current level is programmed into the unit. The GF test procedure on the last page of the installation instructions must be conducted before the device is brought online.

## **PROGRAMMING**

1. Rotate the mode select switch to the parameter to be programmed. SymCom recommends that "LV" be programmed first and then move clockwise through the positions to complete the process.
2. Press and hold the "RESET/PROGRAM" button.
3. Rotate the "DISPLAY/PROGRAM" knob until the proper setting for the parameter that is being programmed is displayed in the LED window.
4. Release the "RESET/PROGRAM" button. This stores the new parameter in the nonvolatile memory. If the number changes back to what it was before programming, then the tamper guard is "on" and will need to be unlocked before programming can be completed. (See page 11 for tamper guard procedures.)
5. Continue steps 1-4 until all parameters are programmed.
6. The programming is now complete. Please see "Operations" section (p.6) for operating the unit.

## Operation

The relay operation of the 777 is a fail safe design. This means when everything is within the limits programmed into the unit, the relay will energize; the normally open (NO) contact will close and the normally closed (NC) contact will open. Once the unit has been wired and programmed, the unit is ready to operate. Turn the mode select to the "RUN" position. The display will show "RUN" alternating with some number (the numbers displayed will be the number corresponding to where the "DISPLAY/PROGRAM" knob is pointed). It will do this for the amount of time programmed into "RD1". After this time has expired, the relay will energize (normally open will close and normally closed contact will open). If something else is in the display, see the troubleshooting section for more information. If the mode select is taken out of the "RUN" position, the units relay will de-energize.

Trip Class	Application Description
5	Small fractional horsepower motors where acceleration times are almost instantaneous or where extremely quick trip times are required.
10	(Fast Trip) Hermetic refrigerant motors, compressors, submersible pumps and general purpose motors that reach rated speed in less than 4 seconds.
15	Specialized applications.
20	(Standard Trip) Most NEMA-rated general purpose motors will be protected by this setting.
30	(Slow Trip) Motors with long acceleration times (>10 seconds) or high inertia loads.
J Prefix	Programming any of the trip classes with the J Prefix will enable jam protection. This additional protection is enabled 1 minute after the motor starts and provides a 2 second trip time for motors exceeding 400% of the "OC" setting, regardless of trip class.

**Table 2: Trip Class Descriptions**

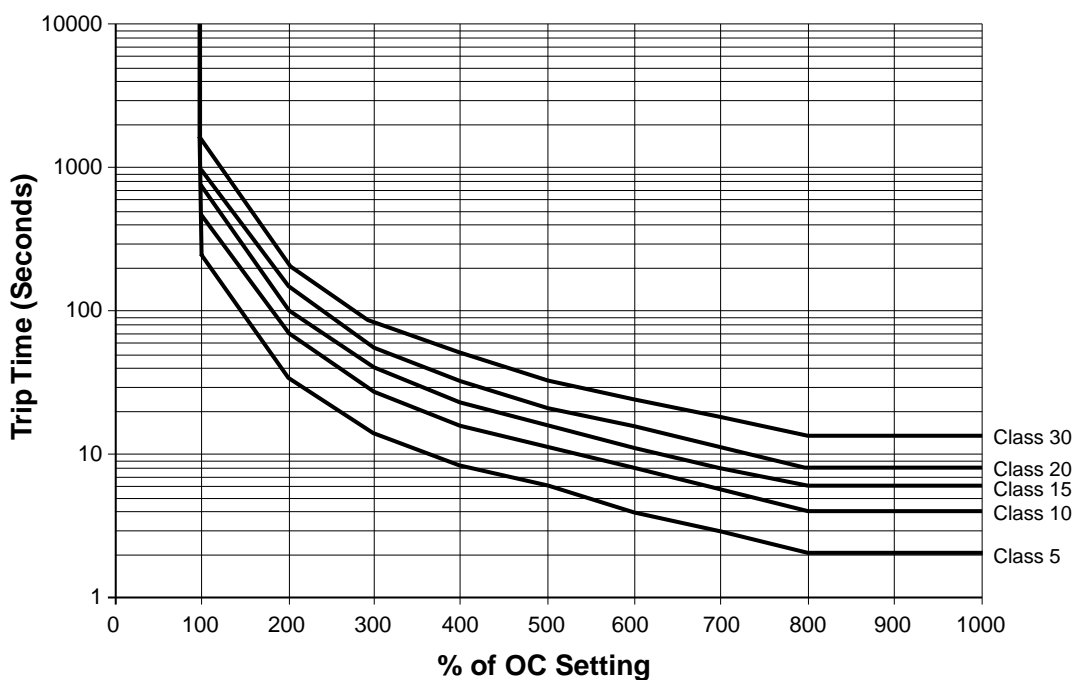

**Figure 4: Overload Trip Curves**

## Programming Examples

### **Example #1**

Motor To Be Protected: 3Ø, 460 Volt, 25 Hp air compressor with a full load amperage rating of 34A and maximum service factor amps of 37.4. Use the following calculations and reasoning to determine the appropriate settings for this application.

- LV-  $460 \times 0.90 = 414$
- HV-  $460 \times 1.10 = 506$
- VUB- Standard NEMA motor = 5
- MULT- From Table No. 1 = 1
- OC- Service Factor Amperage = 37.4
- UC-  $FLA \times 0.80 = 34A \times 0.80 = 27.2$
- CUB- Standard NEMA motor = 5
- TC- General purpose motor = 20
- RD1- Since this compressor takes about 10 seconds to bleed off excess pressure after a shutdown, setting RD1 = 20 will allow the compressor to unload before being restarted.
- RD2- Because the motor may be hot from running in an unbalance or single phase condition, a motor cool down time of 10 minutes, RD2 = 10, should be appropriate.
- RD3/#RU- Because an undercurrent would signal a serious problem in this application (a broken shaft or belt), #RU should be set = 0 for a manual reset. Therefore, RD3 does not have any function
- #RF- Because an overload (overcurrent) fault signals a serious problem in this application (e.g., worn bearings), "oc" should not be included in the #RF setting so that a manual reset after an overload fault is required. A #RF=1 will give the system 1 chance to recover from an unbalance or single phasing problem before manual reset is required.
- UCTD- Setting UCTD = 5 will allow normal operation and not allow the motor to run too long in a failure mode.
- GF- A ground fault setting of 15% of full load amps will be a significant indicator that the motor should be evaluated for repair or replacement. Therefore,  $GF = 34A \times 0.15 = 5.1$ .

### **Example #2**

Motor To Be Protected: 3Ø, 230 Volt, 5 Hp submersible pump with a full load amperage of 15.9 A and maximum service factor amps of 18.2. Use the following calculations and reasoning to determine the appropriate settings for this application.

- LV-  $230 \times 0.90 = 207$
- HV-  $230 \times 1.10 = 253$
- VUB- Manufacturer suggests 5
- MULT - From Table No. 1, MULT = 2, 1 loop of main conductor
- OC- Service Factor Amperage = 18.2
- UC-  $FLA \times 0.80 = 15.9 \times 0.80 = 12.7$
- CUB- Manufacturer suggests 5
- TC- From Figure No. 3, for this (and most) submersible pumps, TC = 10 (fast trip)
- RD1- To protect the pump from rapid cycling, RD1 = 60
- RD2- Since the motor is small and submerged in water, the motor will generally cool down quickly. RD2=5
- RD3- The well history shows that it will fully recover in 2 hours. RD3 = 120
- #RU- In this application, we know that the well will eventually recharge itself, #RU = A.
- #RF- This well is known for sand to jam the impeller, therefore "oc" should be included so that the pump will attempt to automatically restart after an overloaded condition. History shows that 2 or 3 starts and stops usually clears the sand out of the impeller.  
#RF = oc2 or oc3.
- UCTD- This well may become airlocked on startup, but will usually re-prime itself in 5 seconds or less.  
UCTD = 10
- GF- Because this type of fault indicates the impending failure of the motor and it may take several days to get a new pump and schedule for a driller to remove and replace the pump, GF setting of 10% of full load amperage will give the well owner enough time to prepare for pump replacement.  
 $GF = 15.9A \times 0.10 = 1.59$

## System Display

The output display can show one of the following parameters when the “MODE SELECT” switch is pointed at the “RUN” position: average voltage or current, each line current, or each individual line-line voltage. The display is also used for programming the operating parameters of the device. The display also identifies what caused the unit to de-energize its relay or what is keeping the unit from energizing its relay. The last fault, not the current fault, can be displayed by pressing and holding the “RUN/RESET” button while the “MODE SELECT” switch is in the “RUN” position. When the unit trips off or is holding the motor off, the current fault condition will be shown in the display without pressing the button. Table 3 below lists the fault codes the unit could display.

Displayed Message	Meaning
oc	Tripped on Overcurrent
SP	Tripped on current single phasing or unit won't start because the voltage is single phased.
ub	Tripped on current unbalance or unit won't start because the voltage is unbalanced.
uc	Tripped on Undercurrent
CF	Tripped on Contactor Failure
GrF	Tripped on Ground Fault
H I	A high voltage condition exists.
Lo	A low voltage condition exists.
rP	Incoming phases have been reversed. Your motor may run backward if started.
oFF	A stop command was issued from a remote source.

**Table 3: Fault Codes and Their Meaning**

### Communications Port / Remote Reset

The unit comes with a 9-pin sub-D connector for remote communications and/or for using a remotely located reset button.

If communications are desired, a communication module (part number RS485MS) needs to be plugged into this 9-pin connector (this is mandatory when communicating with the unit). This module provides isolation, signal conditioning for compatibility with Modbus RTU and RS485 networks, and provides terminals for terminating the shielded communications cable. Up to 99 units can be installed on one RS485 network. Further information can be obtained at <http://www.symcominc.com> or by calling in your request.

A remote reset button can be hooked up to the communications module (pn RS485MS) or can be hooked directly to the 9-pin connector using a male sub-D connector. It should be wired as shown in figure 5.

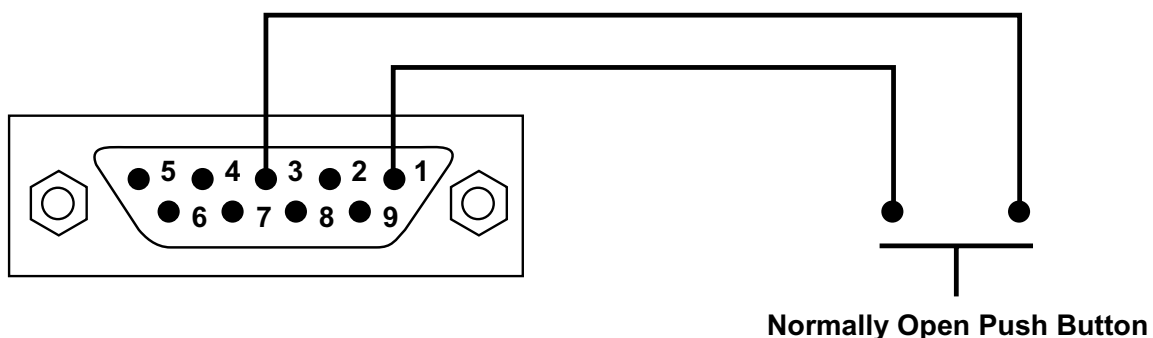

**Figure 5: Remote Reset Button Wiring Diagram**

## Troubleshooting

The MotorSaver will display a fault code alternating with a number or with “run” when it is in a trip condition. If the unit is showing a fault code (see table 4) alternating with the word “run”, then this indicates it has tripped on a current (amperage) condition. If the fault code is alternating with some number (voltage reading or zero) then the unit will not allow the motor to start because there is a problem with the incoming voltage. If the display is showing just a fault code, then the unit is in a mode that requires a manual reset. This could be because the number of restarts (#RF, #RU) has expired or is not allowed. If the display is showing ‘off’ then a stop command was issued through the communications network.

PROBLEM	SOLUTION
The unit will not start. Display alternates “rP” with the “DISPLAY / PROGRAM” switch parameter value.	The voltage inputs are reverse phased. If this is the initial start up, swap any two of the leads connected to “L1”, “L2”, or “L3” on the 777 to correct the problem. If the overload relay has been previously running, the power system has been reverse phased. Check the phase sequence of the incoming power lines. Note: “L1” must be tapped from conductor Phase A, “L2” from B, and “L3” from C for correct power factor measurements on remote communications.
The unit will not start. Display alternates “SP”, “ub”, “HI”, or “Lo” with the “DISPLAY / PROGRAM” switch parameter value.	The incoming voltage is not within the limits programmed in the “VUB”, “HV”, and “LV” settings. Adjust the “DISPLAY / PROGRAM” switch to read the incoming line voltage values. Correct the incoming power problem and check programmed limits to verify they are correct.
Display alternates “SP”, “ub”, or “oc” with “RUN.”	The overload relay has tripped on the fault shown on the LED display and is timing down “RD2” before restarting.
Display alternates “uc” with “RUN.”	The overload relay has tripped on undercurrent and is timing down “RD3” before restarting. If undercurrent is not a normal condition for this installation, check for broken shafts, broken belts, etc.
Display is showing a solid “SP”, “ub”, or “oc.”	The unit has tripped on the fault shown and a manual reset is required because of the programmed setting in “#RF”. Check the system for problems that would produce the single phase, overload or current unbalance fault like a jam.
Display is showing a solid “uc.”	The unit has tripped on undercurrent and a manual reset is required because of the setting in “#RU.” Check the system for problems that would produce a loss of load like a broken belt or a pump is out of liquid.
Display is showing a solid “CF.”	The unit has tripped on a single phasing of the current, but was not single phased by the incoming voltage. Check for damaged contacts or loose wiring.
Display is showing a solid “GrF.”	A ground fault current greater than the programmed “GF” value has been detected. A manual reset is required. Check the motor for insulation breakdown.

**Table 4: Troubleshooting**

# MODEL 777 SPECIFICATIONS

<b>Electrical</b>	
Input Voltage	200-480 VAC, 3Ø(Standard) 500-600VAC for model 777-575
Frequency	50-60 Hz
Motor Full Load Amp Range	2-25 Amps, 3Ø(Loops Required) 25-90 Amps, 3Ø(Direct) 80-800 Amps, 3Ø(External CTs)
Power Consumption	10W (Maximum)
Output Contact Rating SPDT (Form C)	Pilot duty rating: 480 VA @ 240 VAC General purpose: 10A @ 240 VAC
Expected Life	
Mechanical	1 x 10 <sup>6</sup> operations
Electrical	1 x 10 <sup>5</sup> operations at rated load
Accuracy at 25° C (77° F)	
Voltage	±1%
Current	±3%(<100 Amps Direct)
GF Current	±15%
Timing	5% ± 1 second
Repeatability	
Voltage	± 0.5% of nominal voltage
Current	± 1% (<100 amps direct)
Trip Times (Those not shown have user selectable trip times.)	
<u>Ground Fault Trip Time</u> 101%-200% of Setpoint 201%-300% of Setpoint 301%-400% of Setpoint 401% or Greater	<u>Trip time</u> 8 seconds ± 1 second 4 seconds ± 1 second 3 seconds ± 1 second 2 seconds ± 1 second
<u>Current Unbalance Trip Times</u> <u>% Over Setpoint</u> 1% 2% 3% 4% 5% 6% 10% 15%	<u>Trip time</u> 30seconds 15seconds 10seconds 7.5seconds 6seconds 5seconds 3seconds 2seconds
Safety Marks	
UL	UL508, UL1053
CE	IEC 60947-1, IEC 60947-5-1
Standards Passed	
Electrostatic Discharge (ESD)	IEC 1000-4-2, Level 3, 6kV contact, 8kV air
Radio Frequency Immunity (RFI), Conducted	IEC 1000-4-6, Level 3 10V/m
Radio Frequency Immunity (RFI), Radiated	IEC 1000-4-3, Level 3 10V/m
Fast Transient Burst	IEC 1000-4-4, Level 3, 3.5 kV input power
Surge	
IEC	1000-4-5 Level 3, 2kV line-to-line; Level 4, 4kV line-to-ground
ANSI/IEEE	C62.41 Surge and Ring Wave Compliance to a level of 6kV line-to-line
Hi-potential Test	Meets UL508 (2 x rated V + 1000V for 1 minute)
Vibration	IEC 68-2-6, 10-55Hz, 1mm peak-to-peak, 2 hours, 3 axis
Shock	IEC 68-2-27, 30g, 3 axis, 11ms duration, half-sine pulse

# MODEL 777 SPECIFICATIONS

<b>Mechanical</b>	
Dimensions	3.0"H x 5.1 " D x 3.6"W
Terminal Torque	7 inch•lb
Enclosure Material	Polycarbonate
Weight	1.2lbs
Maximum Conductor Size Through 777	0.65" with insulation
<b>Environmental</b>	
Temperature Range	Ambient Operating: -20° - 70° C (-4° - 158°F) Ambient Storage: -40° - 80° C (-40° - 176°F)
Pollution Degree	3
Class of Protection	IP20, NEMA 1
Relative Humidity	10-95%, non-condensing per IEC 68-2-3
<b>Programmable Operating Points</b>	
	<b>Range</b>
LV- Low Voltage Threshold	170V (450V*) - HV Setting
HV- High Voltage Threshold	LV Setting - 528V (660V*)
UB- Voltage Unbalance Threshold	2 - 15% or 999%
MULT- # of Loops or CT Ratio (XXX:5)	1-10 Loops or 100-800 Ratio
OC- Over Current Threshold	(20 to 100A) ÷ MULT or 80 to 120% of CT Primary
UC- Under Current Threshold	(0, 10 to 98A) ÷ MULT or 40 to 100% of CT Primary
CUB- Current Unbalance Threshold	2 - 25% or 999%
TC- Over Current Trip Class **	5, J5, 10, J10, 15, J15, 20, J20, 30, J30
RD1- Rapid Cycle Timer	0, 2 - 500 Seconds
RD2- Restart Delay After All Faults Except Under Current (motor cool down timer)	2 - 500 Minutes
RD3- Restart Delay After Under Current (dry well recovery timer)	2 - 500 Minutes
#RU- Number of Restarts After Under Current	0, 1, 2, 3, 4, A(Automatic)
ADDR- RS485 Address	A01-A99
#RF-Number of Restarts After All Faults Except Undercurrent***	0, 1, oc1, 2, oc2, 3, oc3, 4, oc4, A, ocA
UCTD- Under Current Trip Delay	2 - 60 Seconds
GF- Ground Fault Current Threshold	(3 to 20A) ÷ MULT or 10 to 30% of CT Primary or OFF

**NOTES:** SymCom's Overload Relay can be preprogrammed prior to installation by applying 120 VAC between the L1 and L2 terminals (except 575 Volt model). Power applied must be 110 VAC or greater.

\* 575 Volt Model.

\*\* If J Prefix is displayed in trip class setting, jam protection is enabled.

\*\*\* If "oc" is displayed in the #RF setting, then Over Current will be included as a normal fault and the relay will automatically restart after RD2 expires, otherwise, manual reset is required after an Over Current fault.

## **Tamper Guard**

The MotorSaver can be protected from unauthorized program changes by locking in the setpoints. This procedure is outlined as follows:

1. Rotate the Mode Select switch to 'GF'.
2. Rotate Display/Program adjustment fully clockwise.
3. Press and hold the Reset Button. Adjust the Display/Program adjustment until 'Loc' appears in the display.
4. Release the Reset Button.
5. Turn Mode Select switch to 'run'.

The program is now locked, but all settings can be viewed. The unit can be unlocked by following the procedure above except step three. This step should say: Press and hold the Reset Button. Adjust the Display/Program adjustment until 'unL' appears in the display.

The GF test must be performed before installing the MotorSaver as required by UL1053 and NEC, ANSI/NFPA 70.

**Ground Fault Testing Procedure**

1. Disconnect power
2. Hook up the three line voltages to L1, L2, and L3 as required by the installation instructions.
3. Program the desired parameters into the unit. For test purposes, set MULT to one and GF to the minimum allowed setting.
4. Construct the circuit below, using an AC power supply. This circuit simulates a ground fault condition by generating a current in one of the phases. Alternate test circuits may be used. The only requirement is the current through the current transformer must be between 115% and 150% of the GF setting and pass through only one CT window.

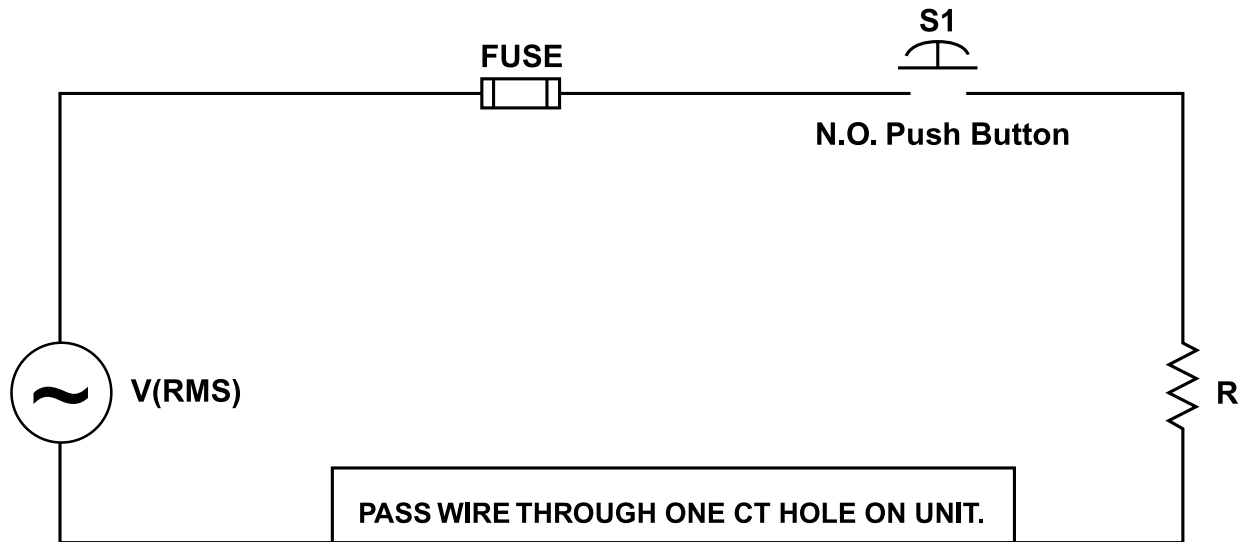

5. The values of V and R will be determined by the current required to generate a GF trip condition:  $I = V_{rms}/R$ , where  $I = 115\%$  of GF setting.
6. Place the unit in the run position, apply three phase power and allow the N.O. contact to close.
7. Energize the test circuit by pushing and holding the test push-button until the unit trips (within 8.5 seconds). The display should show GrF and the N.O. contacts should be open. Release the N.O. push button.
8. The results of the test are to be recorded on the test form provided. The form should be kept by those in charge of the buildings electrical installation in order to be available to the authority having jurisdiction.
9. Confirm programmed parameters and proceed with installation instructions.

-----  
**Ground Fault Test Results\***

<u>Date</u>	<u>Performed by</u>	<u>Results</u>	<u>Location</u>
-------------	---------------------	----------------	-----------------

\*A copy of this form should be retained by buildings electrical foreman.

SymCom Warrants its microcontroller based products against defects in material or workmanship for a period of five (5) years from the date of manufacture. All other products manufactured by SymCom shall be warranted against defects in material and workmanship for a period of two (2) years from the date of manufacture. For complete information on warranty, liability, terms, returns, and cancellations, please refer to the SymCom Terms and Conditions of Sale document.