

Euro-HYGIA®



Fig. 1 Euro-HYGIA®

Technical data

Euro-HYGIA® I and II

Head:	up to 70 m
Flow rate:	up to 108 m ³ /h
(Euro-HYGIA® III - on request):	up to 250 m ³ /h
Operating pressure:	up to 16 bar
Operating temperature:	95°C
	(up to 150°C on request)
Sterilisation temperature:	140°C (SIP)

Applications

The unique hygienic design and the use of materials make the Euro-HYGIA® pump range suitable for:

Food and beverage industry

- Liquid transfer in breweries and dairies
- Mixing in soft drink applications
- Food processing plants.

Pharmaceutical industry

- Pure water systems (WFI)
- Biotechnology
- Cosmetics.

Other industrial applications

- Semi-conductor manufacturing
- CIP (Cleaning-In-Place) systems.

Construction

Euro-HYGIA® pumps are single-stage, end-suction centrifugal pumps designed to meet the hygienic requirements of sterile process technology. The pumps are CIP and SIP capable in compliance with the DIN EN 12462 performance criteria.



The design of the wetted parts meets the Qualified Hygienic Design (QHD) standard, EHEDG test certificate for CIP cleanability (TNO), 3A sanitary standard (USA) and GOST (Russia).

The pump housing is made of heavy-duty, rolled and deep-drawn CrNiMo steel DIN EN 1.4404/1.4435, equivalent to AISI 316L.

Three impeller types are available depending on the application: Semi-open, closed and free-flow impeller. For further information, see page 19.

The pumps have a mechanical shaft seal and a fan-cooled asynchronous motor with enclosure class IP 55.

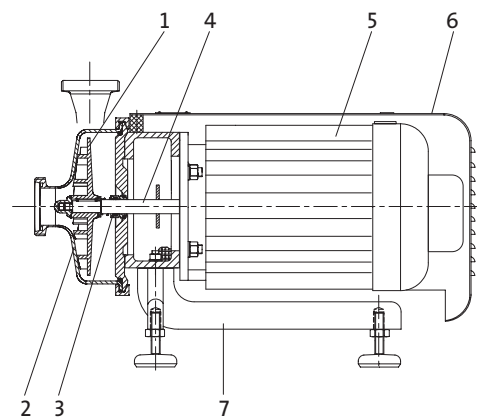

Fig. 2 Sectional drawing of Euro-HYGIA® I Bloc-SUPER on combi-foot

Materials

Pos.	Component	Material	DIN EN
1	Impeller	CrNiMo steel	1.4404/ 1.4435
2	Pump housing	CrNiMo steel	1.4404/ 1.4435
3	Shaft seal	Sterile applications: SiC/SiC/EPDM Hygienic applications: Carbon/ stainless steel/EPDM or FKM	
4	Pump shaft	CrNiMo steel	1.4571
5	Motor		
6	Shroud	Stainless steel	
7	Support	Stainless steel/cast iron	

Design variations

Grundfos offers the below design variations for Euro-HYGIA® pumps:

Standard variation	Short description
Euro-HYGIA® Adapta®	Horizontal installation, Adapta® motor stool
Euro-HYGIA® Adapta® SUPER	Horizontal installation, Adapta® motor stool, motor with stainless steel shroud
Euro-HYGIA® Bloc	Horizontal installation
Euro-HYGIA® Bloc-SUPER	Horizontal installation, motor with stainless steel shroud
Variations on request	Short description
Euro-HYGIA® Adapta®-V	Vertical installation, Adapta® motor stool
Euro-HYGIA® Bloc-V	Vertical installation
Euro-HYGIA® CN	Horizontal installation, long-coupled version mounted on baseplate
Euro-HYGIA® tronic	Horizontal/vertical installation, motor with built-in frequency converter (up to 7.5 kW)

For further information, see page 23.

Mechanical shaft seal

Grundfos offers the following three seal arrangements as standard:

- single seal
- double tandem seal
- double back-to-back seal.

The mechanical shaft seals used are single inboard mechanical shaft seals with an optimum position in the pumped liquid. This ensures lubrication, cooling as well as CIP and SIP according to the criteria of hygienic design.

Standard seals have seal faces of carbon/stainless steel and O-rings of EPDM.

On request Grundfos offers other seal face material combinations.

For further information, see page 20.

Surface treatment

As standard all wetted parts are electro-polished to improve corrosion-resistance and surface finish.

Connections

Depending on the nominal diameter of the Euro-HYGIA® pump, Grundfos offers the following pipe connections as standard:

- Threads to DIN 11851, PN 25-40
- Flanges to DIN EN 1092-1, PN 10 (DIN 2633/42, PN 10) (industrial applications only)
- Pipe threads to DIN ISO 228, PN 10 (max.)
- Sterile threads to DIN 11864-1, PN 16
- Sterile flanges to DIN 11864-2, PN 16.

Other connections are available on request, e.g. SMS, RJT, clamp connections to DIN, ISO, Tri-Clover, special sterile threaded fittings and flanges.

For further information about pipe connections for Euro-HYGIA® pumps, see page 27 to 28.

Product features and benefits

Euro-HYGIA® pumps offer the following product features and benefits:

- A wide range of support possibilities for both motor and pump.
- Extremely reliable operation under most working conditions.
- Optimised hydraulics for high efficiency - reduced power consumption.
- MultiFunction inducer for NPSH reduction or pumping of liquids containing gas (Euro-HYGIA® II).
- Motors for special voltages and frequencies.
- Euro-HYGIA® Adapta® and Euro-HYGIA® CN with explosion- or flameproof three-phase motors are available for ATEX-applications.
- Motors for variable speed drive with built-in frequency converter as "tronic". Available for motor sizes up to 7.5 kW.
- Mobile pumps mounted on two-wheel stainless steel trolley with on/off switch and electric cable.
- DN 15 diaphragm valve drain for sterile processes.
- DN 15 drain connection.
- Heating jacket for pump housing.
- Integral flange ring for bolted housing closure (HPM).
- Special paint finish for drive and cast iron or steel parts.