



### Construction

Horizontal multi-stage close coupled pumps in **chrome-nickel stainless steel**.

Compact and robust construction, without protruding flange and with single-piece lantern bracket and base.

Single-piece barrel casing, with front suction port above pumps axis and radial delivery at top.

Filling and draining plugs on the middle of the pump, accessible from any side (like the terminal box).

### Applications

For water supply.

For clean liquids, without abrasives, which are non-aggressive for stainless steel (with suitable seal materials, on request).

Universal pump, for domestic use, for civil and industrial applications, for garden use and irrigation.

### Operating conditions

Liquid temperature from - 15 °C to + 110 °C.

Ambient temperature up to 40 °C.

Maximum permissible pressure in the pump casing: 10 bar.

Continuous duty.

### Motor

2-pole induction motor, 50 Hz (n = 2900 rpm).

**MXH:** three-phase 230/400 V ± 10%.

**MXHM:** single-phase 230 V ± 10%, with thermal protector.

Capacitor inside the terminal box.

Insulation class F.

Protection IP 54.

Constructed in accordance with: IEC 34;

IEC 38;

IEC 335-1, EN 60335-1;

IEC 335-2-41, EN 60335-2-41;

EN 60529.

### Special features on request

- Other voltages.
- Frequency 60 Hz (as per 60 Hz data sheet).
- Protection IP 55.
- Special mechanical seal
- Pump casing seal rings in FPM (Viton).
- Higher or lower liquid or ambient temperatures.

### Materials

Component	Material
Pump casing	Chrome-nickel steel 1.4301 EN 10088 (AISI 304)
Stage casing	Chrome-nickel steel 1.4301 EN 10088 (AISI 304)
Wear ring	PTFE (Teflon)
Impeller	Chrome-nickel steel 1.4301 EN 10088 (AISI 304)
Casing cover	Chrome-nickel steel 1.4301 EN 10088 (AISI 304)
Spacer sleeve	Chrome-nickel steel 1.4301 EN 10088 (AISI 304)
Pump shaft	Chrome-nickel steel 1.4305 EN 10088 (AISI 303)
Plug	Chrome-nickel steel 1.4305 EN 10088 (AISI 303)
Mechanical seal with seat according to ISO 3069	Ceramic alumina, carbon, EPDM (Other materials on request)

### Coverage chart $n \approx 2900$ rpm

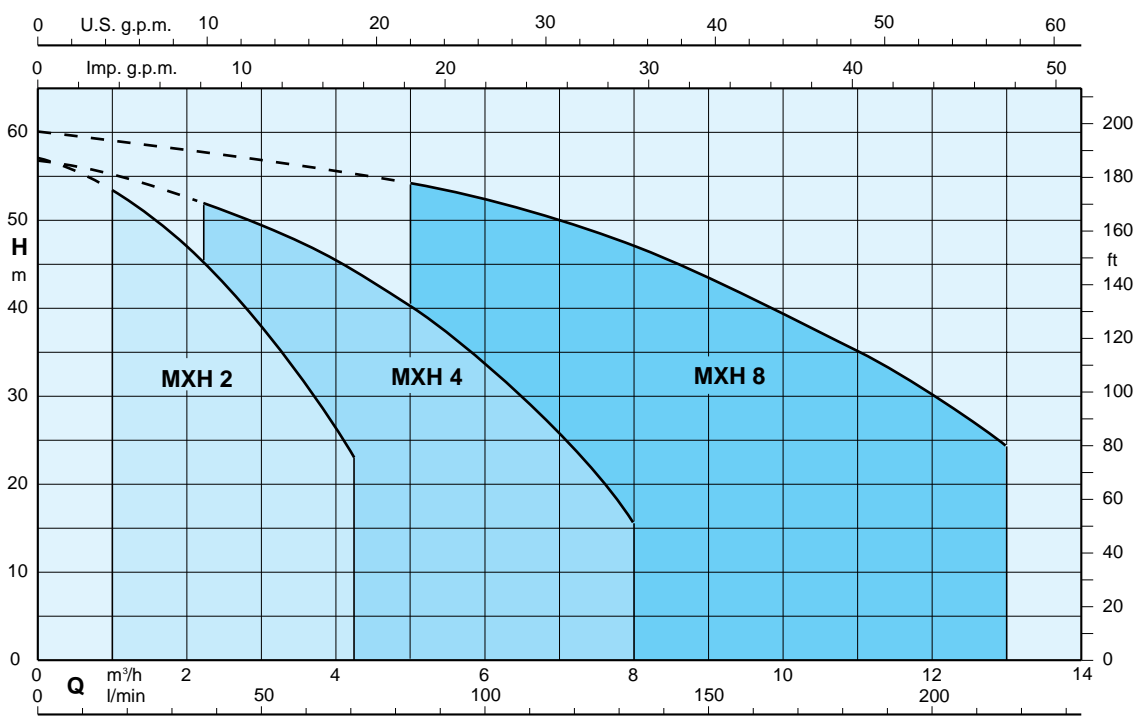

### Performance $n \approx 2900$ rpm

	3 ~ 230 V 400 V		1 ~ 230 V		P1		P2		Q m <sup>3</sup> /h l/min	0	1	1,5	2	2,5	3	3,5	4	4,25
	A	A	A	kW	kW	HP	0	1		1,5	2	2,5	3	3,5	4	4,25		
MXH 202E	1,7	1	MXHM 202E	2,3	0,5	0,33	0,45	22	20,5	19	18	16	14	11,5	9	8		
MXH 203E	2,4	1,4	MXHM 203E	3	0,65	0,45	0,6	33	31	29	27	24	21,5	18	14,5	12,5		
MXH 204E	2,8	1,6	MXHM 204E	4,2	0,9	0,55	0,75	45	42,5	40	37,5	34	30	25,5	21	18		
MXH 205E	3,5	2	MXHM 205E	5,4	1,2	0,75	1	57	53,5	50,5	47	43	38	32,5	26,5	23		

	3 ~ 230 V 400 V		1 ~ 230 V		P1		P2		Q m <sup>3</sup> /h l/min	0	2,25	3	3,5	4	4,5	5	6	7	8
	A	A	A	kW	kW	HP	0	2,25		3	3,5	4	4,5	5	6	7	8		
MXH 402E	2,4	1,4	MXHM 402E	3	0,65	0,45	0,6	22,5	20	19,5	18,5	17,5	16	15	12,5	9,5	6		
MXH 403E	2,8	1,6	MXHM 403E	4,2	0,9	0,55	0,75	33	30	29	27,5	26	24,5	23	19,5	15	9,5		
MXH 404E	3,5	2	MXHM 404E	5,4	1,2	0,75	1	44,5	40,5	38	36,5	35	33	31	26	20	12,5		
MXH 405E	4,7	2,7	MXHM 405	7,4	1,5	1,1	1,5	56,5	52	50	47,5	45,5	43	40	33,5	26	16,5		

	3 ~ 230 V 400 V		1 ~ 230 V		P1		P2		Q m <sup>3</sup> /h l/min	0	5	6	7	8	9	10	11	12	13
	A	A	A	kW	kW	HP	0	5		6	7	8	9	10	11	12	13		
MXH 802E	3,7	2,2	MXHM 802E	5,7	1,2	0,75	1	22,5	20,5	20	19	18	16,5	15	13	11	8,5		
MXH 803	5	2,9	MXHM 803	7,4	1,5	1,1	1,5	36	32	30,5	29	27,5	25,5	23	20	17	14		
MXH 804	6,4	3,7	MXHM 804	9,2	2	1,5	2	48	42,5	41	39	37	34,5	32	28	24	19,5		
MXH 805	7,5	4,3				1,8	2,5	60	54	52	49,5	47	43,5	39,5	35	29,5	24		

P1 Max. power input.

Test results with clean cold water, without gas content.

P2 Rated motor power output.

Tolerances according to ISO 9906, annex A.

### Dimensions and weights

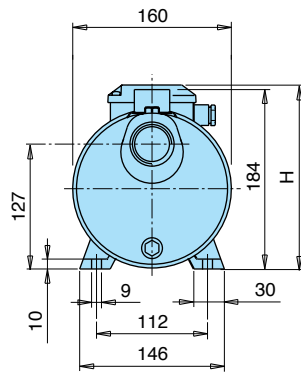
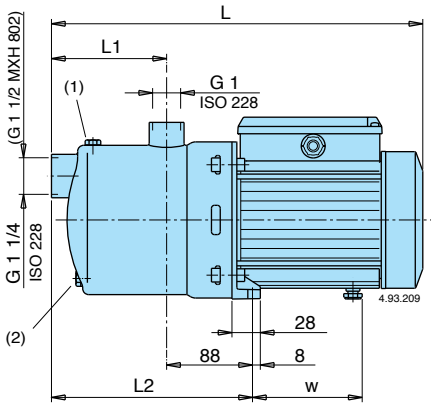

TYPE	mm					kg	
	L	L1	L2	H	w	MXH	MXHM
MXH 202E - MXHM 202E	331	94	182	176	98,5	6,8	6,9
MXH 203E - MXHM 203E	331	94	182	176	98,5	7,6	7,7
MXH 204E - MXHM 204E	381	118	206	189	112	10	11
MXH 205E - MXHM 205E	405	142	230	189	112	11,5	12,5
MXH 402E - MXHM 402E	331	94	182	176	98,5	7,6	7,7
MXH 403E - MXHM 403E	357	94	182	189	112	9,3	10,3
MXH 404E - MXHM 404E	381	118	206	189	112	10,8	11,8
MXH 405E	405	142	230	189	112	13	
MXH 802E - MXHM 802E	381	118	206	189	112	10,6	11,6

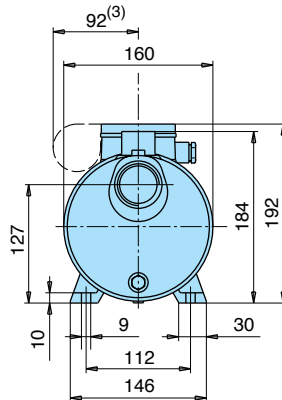
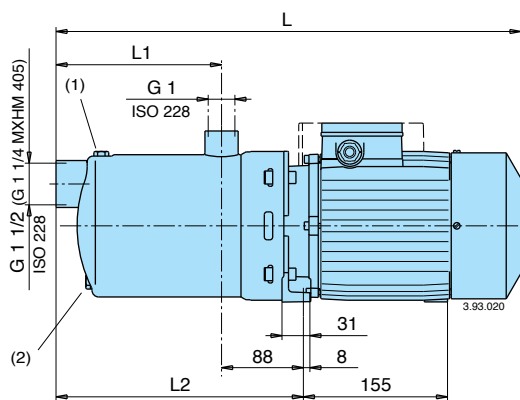

TYPE	mm			kg	
	L	L1	L2	MXH	MXHM
MXHM 405	464	142	230		18
MXH 803 - MXHM 803	440	118	206	15,8	16,9
MXH 804 - MXHM 804	470	148	236	18,2	19,2
MXH 805	500	178	266	19	

(1) Filling

(2) Draining

(3) MXHM

### Characteristic curves $n \approx 2900$ rpm

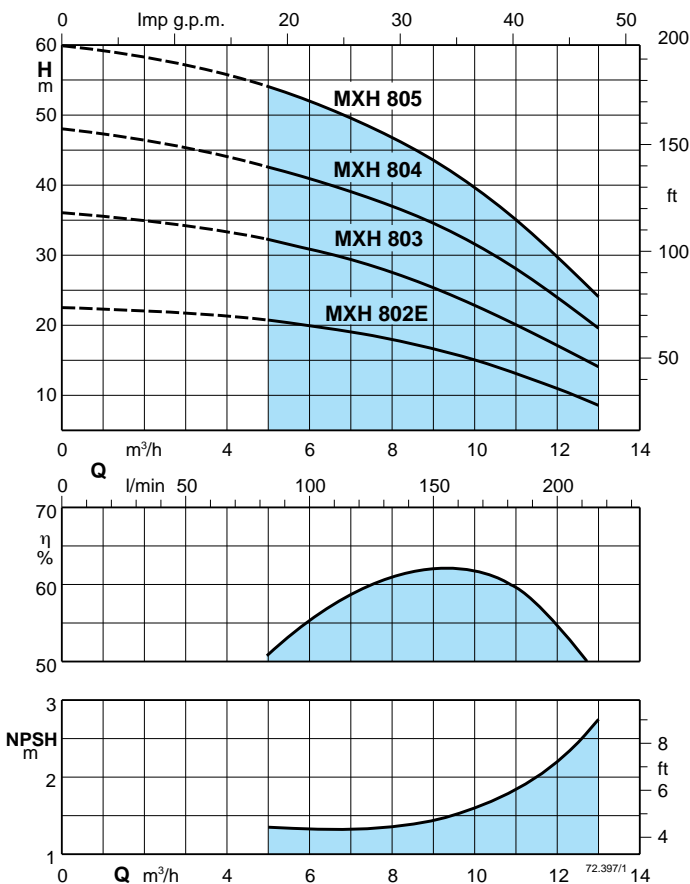
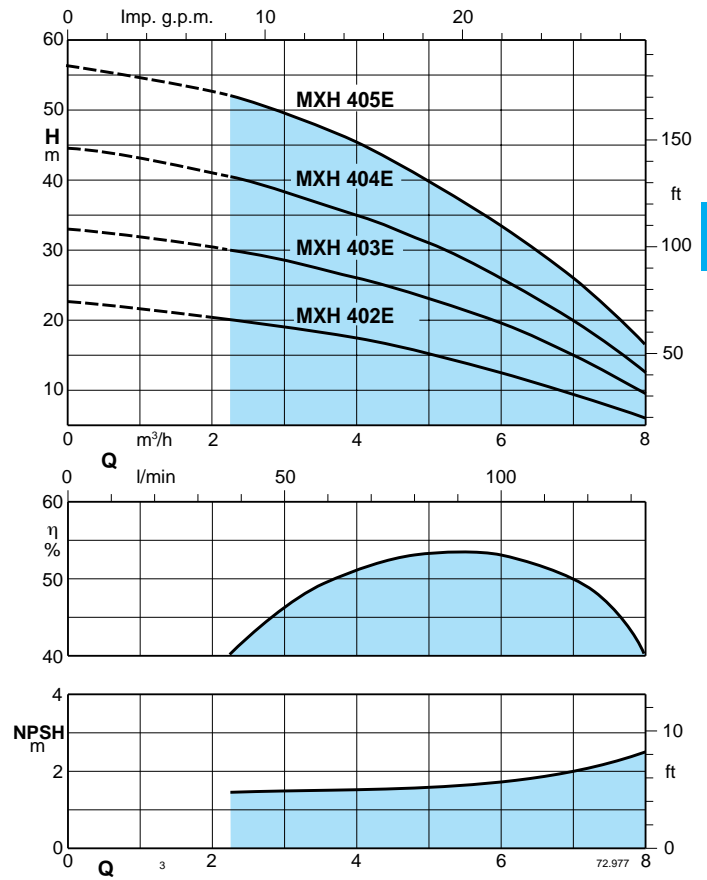
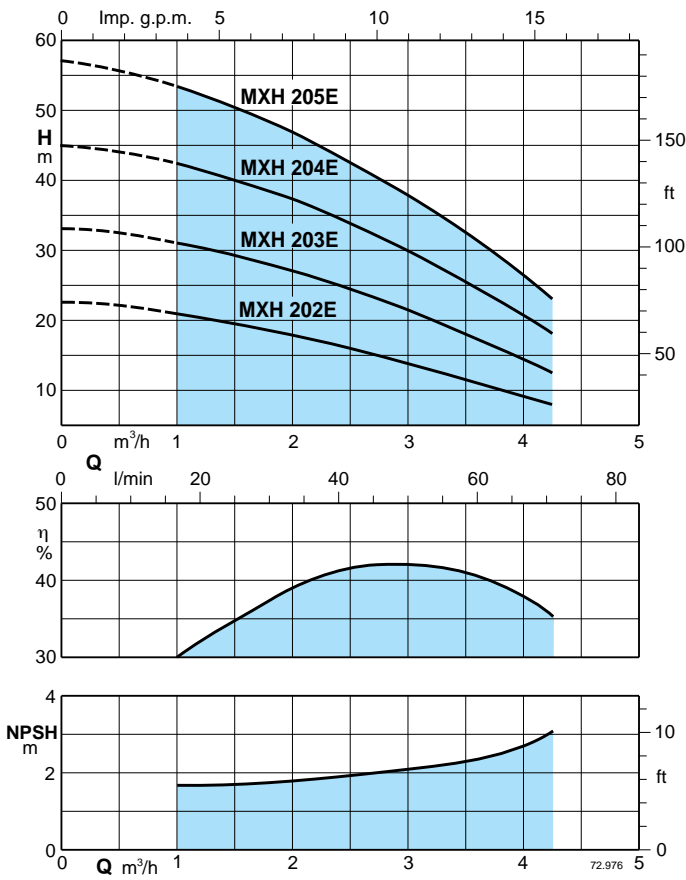

Test results with clean cold water, without gas content.  
+ 0,5 m security margin on NPSH-value is necessary.  
Tolerances according to ISO 9906, annex A.

## Features

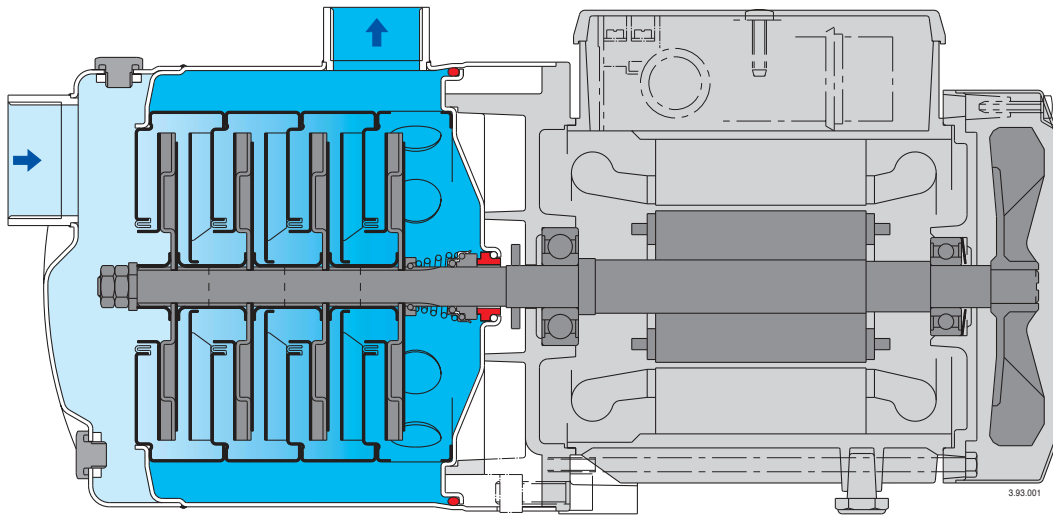

- **Extra safety**  
against running dry, with the suction port above pump axis.
- **Reliable**  
All hydraulic parts in contact with the pumped liquid are of stainless steel.  
For liquids from -15 °C to 110 °C.
- **Robust**  
Single-piece, thick barrel casing.
- **Compact**  
Single-piece lantern bracket and base.  
Without protruding flange.
- **Greater protection**  
against leakage, with the pump casing cover separated from the motor shield. Possibility of inspecting the seal through the side apertures between the two walls.  
Greater protection against water entering the motor from outside provided by an extension of the pump casing around the lantern bracket.