



DIGITAL DOSING™ up to 150 l/h

By popular demand, we have applied innovative technology to expand the Digital Dosing™ pump range, allowing it to handle liquids in much larger quantities. With just two models the new DME range can cover the range from 75 ml/h to 150 l/h. Perfect for large water and wastewater treatment plants, textile industries, pulp and paper industries, and many other demanding applications, the new, large DME pumps bring the benefits of Digital Dosing™ to a new circle of users worldwide.

Familiar Digital Dosing™ benefits

The 60 – 150 l/h pump range has all the benefits of the highly acclaimed smaller Digital Dosing™ range, making exact dosing easier than ever.

Easy-to-use digital user interface

The simple display allows everyone to be their own dosing specialist. With just a few buttons, you can navigate the straightforward menus to use the impressive range of standard control features – including pulse, analog, timer, batch, and anti-cavitation control – as well as simple calibration and much more.

Turndown ratio 1:800

With a turndown ratio ten times better than that of traditional equipment, the large Digital Dosing™ pumps give you greater flexibility and accuracy than ever. Only two pump sizes cover the range from 75 ml/h – 150 l/h.

Full stroke length at all times

Grundfos AllDOS is the only pump manufacturer to use a full stroke length every time. The strokes are carefully timed, ensuring even concentration in the system and optimal priming throughout the entire operating range.

Brushless DC motor ensures full control

The ingenious design of the large Digital Dosing™ pumps eliminates the need for a servo motor/frequency converter and ensures smooth and gentle dosing.

Anti-cavitation

Turndown of the suction stroke to 75%, 50% or 25% of the maximum speed ensuring optimal priming and displacement of even the most difficult liquids.

Fieldbus communication available

Available with Profibus interface to supply performance data and status information for quality control, preventive maintenance and future reference.

Overload protection

Built-in overload protection monitors pump counter pressure and protects against exceptionally high pressure loads.

Switch-mode power supply

The switch-mode power supply ensures that the Digital Dosing™ pumps can be used worldwide within the 100–240VAC – 50/60Hz range.

Several material variants

The DME pump heads are available in stainless steel, PVDF, and environmentally friendly, cost-efficient polypropylene.

Dimensions (mm)

	DME 60-10	DME 150-4
A	198	198
B	176	176
C	331	345
D	284	284
E	180	180
F	444	444
G	41	28
H	74	74
I	187	187

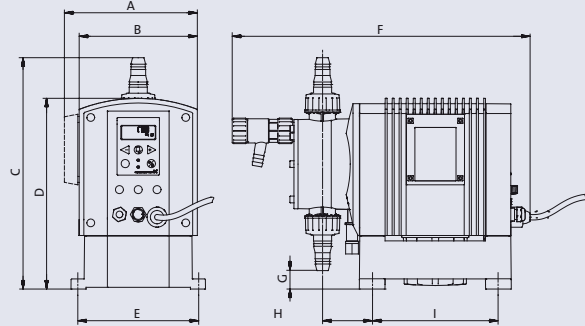

Product range and performance data

Pump type		DME 60-10	DME 150-4
Max. capacity at max. pressure	[l/h]	60	150
Min. capacity	[l/h]	0.075	0.188
Max. pressure	[bar]	10	4
Setting range		1:800	
Stroke frequency	[min ⁻¹]	160	
Power supply	[V], [Hz]	1×100-240V, 50-60 Hz	
Accuracy	[%]	±1% repeatability	
Pumphead material		PP, PVDF, stainless steel	
Suction lift	[m]	4	
Viscosity*	[mPa]	3000 at 50% capacity	

* Spring-loaded valves

Performance range

